

Information Technologies: Concepts and Management

Management Information



- Code: 164292-02
- Course: Management Information
- Period: Autumn 2013
- Professor: Sync Sangwon Lee, Ph. D
- D. of Information & Electronic Commerce

00. Contents

- 01. Information System
- 02. Environments
- 03. Inter-Organizational Systems
- 04. Information Infrastructure
- 05. Internet
- 06. Corporate Portals
- 07. E-commerce Systems
- 08. Enterprise Web
- 09. New Computing Environments
- 10. Managing Information Systems

01. Information System

- Concepts and Definitions
 - An information system (IS) collects, processes, stores, analyzes, and disseminates information for a specific purpose (Application).

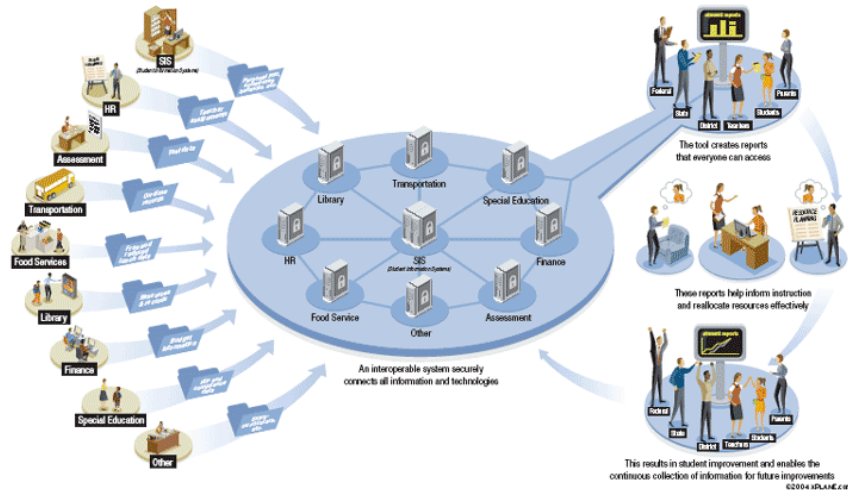

<http://www2.ed.gov>

01. Information System

- Components
 - Hardware
 - Software
 - Data
 - Network
 - Procedures
 - People

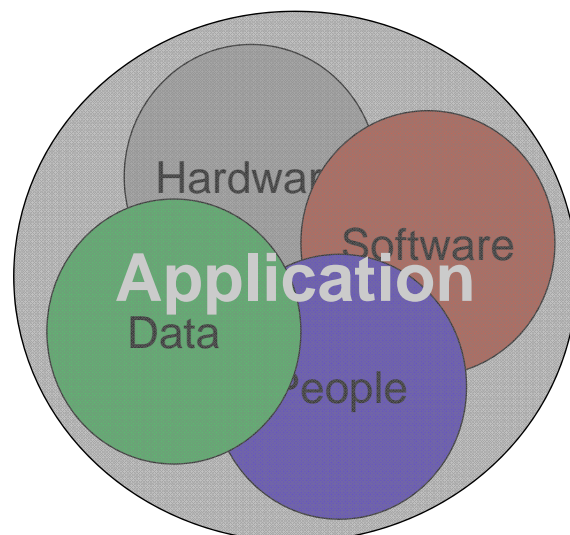

01. Information System

- Primary Purpose
 - Collects data, processes it into information then converts information into knowledge for a specific purpose.



01. Information System

- Data
 - Elementary description of things, events, activities, and transactions that are recorded, classified, and stored, but not organized to convey any specific meaning
- Information
 - Data that has been organized so that they have meaning and value to the recipient
- Knowledge
 - Information that has been organized and processed to convey understanding, experience and expertise as they apply to a current problem or activity

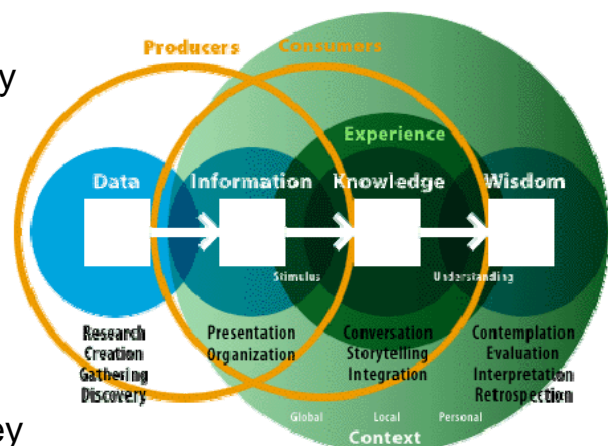

01. Information System

- Classification By Organizational Structure

- An information system (IS) can span departments, business units and corporations.

- Departmental IS
- Enterprise-Wide IS
- Inter-Organizational IS

Information systems are usually connected by means of electronic networks!

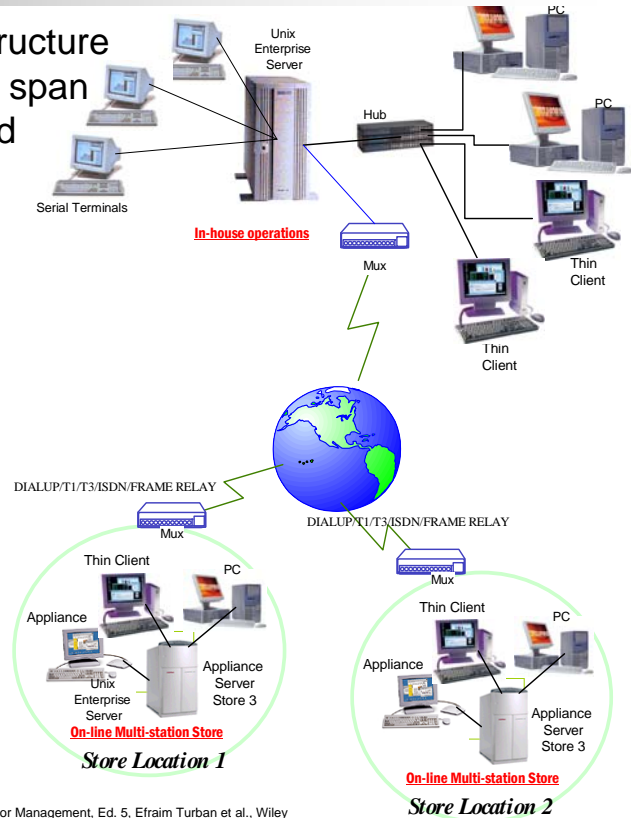

01. Information System

- Classification By Function (Department)

- An information system (IS) support each department in a corporation.

- Human resources
- Operations
- Accounting
- Finance
- Marketing

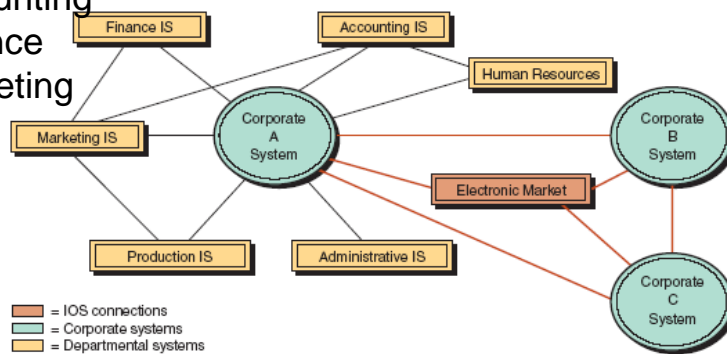

01. Information System

• Classification By Support Function

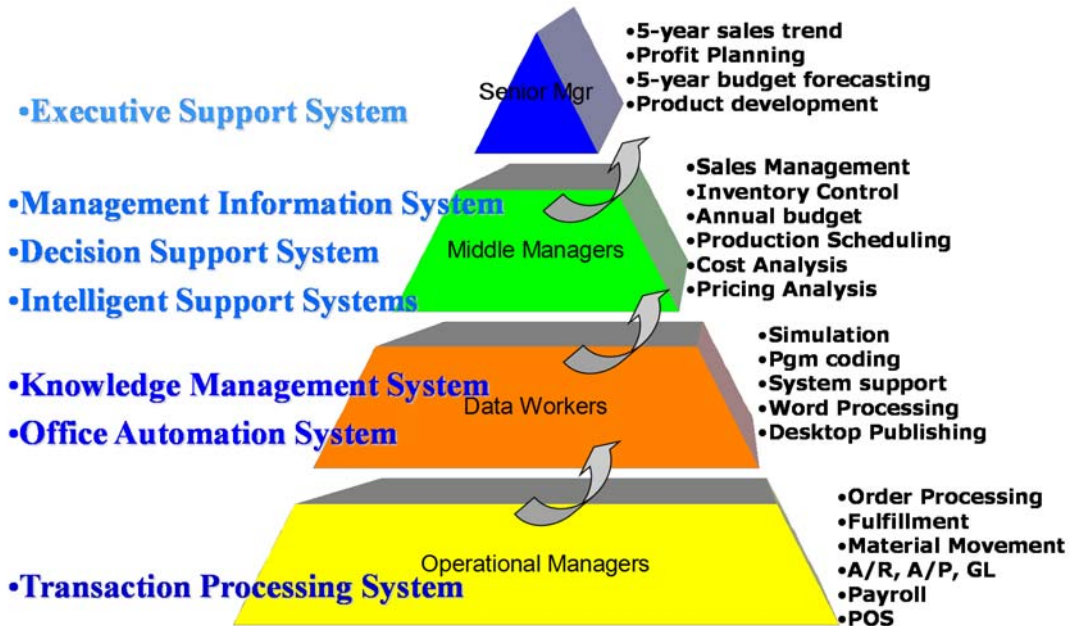

01. Information System

• Classification By Support Function

System	Employees Supported	Description
Transaction processing system (TPS)	All employees	Processes an organization's basic business transactions (e.g., purchasing, billing, payroll).
Management information system (MIS)	All employees	Provides routine information for planning, organizing, and controlling operations in functional areas.
Office automation system (OAS)	Office workers	Increases productivity of office workers; includes word processing.
Word processing system	Office workers	Helps create, edit, format, distribute, and print documents.
CAD/CAM	Engineers, draftspeople	Allows engineers to design and test prototypes; transfers specifications to manufacturing facilities.
Communication and collaboration systems (e.g., e-mail, voice mail, call centers, others)	All employees	Enable employees and customers to interact and work together more efficiently.
Desktop publishing system	Office workers	Combines text, photos, graphics to produce professional-quality documents.
Document management system (DMS)	Office workers	Automates flow of electronic documents.
Decision support system (DSS)	Decision makers, managers	Combines models and data to solve semistructured problems with extensive user involvement.
Executive support system (ESS)	Executives, senior managers	Supports decisions of top managers.
Group support system (GSS)	People working in groups	Supports working processes of groups of people (including those in different locations).
Expert system (ES)	Knowledge workers, nonexperts	Provides stored knowledge of experts to nonexperts and decision recommendations based on built-in expertise.
Knowledge work system (KWS)	Managers, knowledge workers	Supports the gathering, organizing, and use of an organization's knowledge.
Neural networks, case-based reasoning	Knowledge workers, professionals	Learn from historical cases, even with vague or incomplete information.
Data warehouse	Managers, knowledge workers	Stores huge amounts of data that can be easily accessed and manipulated for decision support.
Business intelligence	Decision makers, managers	Gathers and uses large amounts of data for analysis by DSS, ESS and intelligent systems.
Mobile computing systems	Mobile employees	Support employees who work with customers or business partners outside the physical boundaries of the organization.

Supporting Environments!

01. Information System

- Transaction Processing Systems (TPS):
 - TPS automates routine and repetitive tasks that are critical to the operation of the organization, such as preparing a payroll, billing customers, Point-of-Sale and Warehouse operations.
 - Data collected from this operation supports the MIS and DSS systems employed by Middle Management
 - Computerizes the primary and most of the secondary activities on the Value Chain.
 - Primary purpose to perform transactions and collect data.
 - Ex. Point-of-Sale (POS)



<http://www.unrealstudio.com>

11

01. Information System

- Management Information Systems (MIS)
 - These systems access, organize, summarize, and displayed information for supporting routine decision making in the functional areas. Geared toward middle managers, MIS are characterized mainly by their ability to produce periodic reports such as a daily list of employees and the hours they work, or a monthly report of expenses as compared to a budget
 - Typical uses would be in Replenishment, Pricing Analysis (Markdowns) and Sales Management
 - Decisions supported are more structured.
 - Primary purpose to process data into information

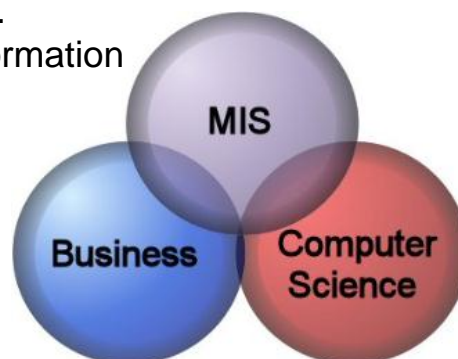

12

01. Information System

- Decision Support Systems (DSS)
 - These systems support complex non-routine decisions.
 - Primary purpose to process data into information
 - DSS systems are typically employed by tactical level management whose decisions and what-if analysis are less structured.
 - This information system not only presents the results but also expands the information with alternatives.
 - Some DSS methodologies
 - Mathematical modeling
 - Simulation
 - Queries
 - What-If (OLAP-cubes)
 - Data mining



13

01. Information System

- Intelligent Support Systems (ISS)
 - Essentially, artificial intelligence (AI) these systems perform intelligent problem solving.
 - Expert systems (ESs)
 - One application of AI is expert systems.
 - It provides the stored knowledge of experts to non-experts, so the latter can solve difficult or time-consuming problems.
 - These advisory systems differ from TPS, which centered on data, and from MIS and DSS, which concentrated on processing information.
 - With DSS, users make their decisions according to the information generated from the systems.
 - With ES, the system makes recommended decisions for the users based on the built-in expertise and knowledge.



<http://www.swictech.com>

14

01. Information System

- Executive Support Systems (ESS)
 - ESS systems or Enterprise Information Systems (EIS) originally were implemented to support Senior management. These systems have been expanded to support other managers within the enterprise.
 - At the senior management level they support Strategic activities which deal with situations that significantly may change the manner in which business is done.

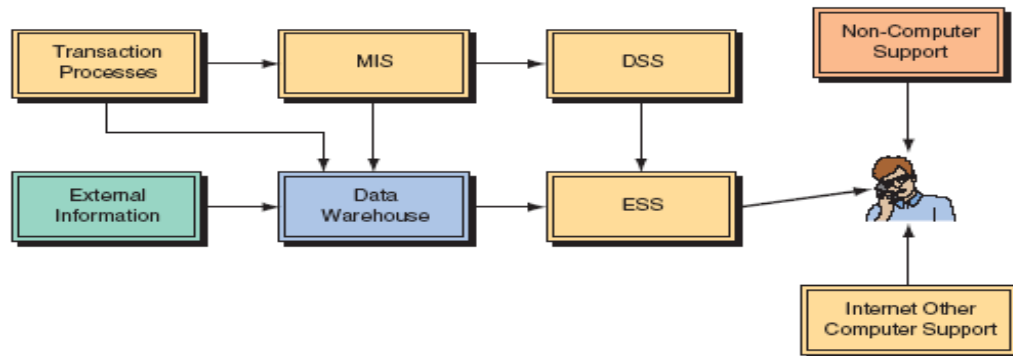

Information Technology for Management, Ed. 5, Efraim Turban et al., Wiley

01. Information System

- Office Automation Systems (OAS)
 - Electronic communication is only one aspect of what is now known as an office automation system (OAS). Other aspects include word processing systems, document management systems and desktop publishing systems.
 - OAS systems are predominantly used by clerical workers who support managers at all levels. Among clerical workers, those who use, manipulate, or disseminate information are referred to as data workers.



<http://www.mbaknol.com>

01. Information System

- Knowledge Management Systems (KMS)
 - An additional level of staff support now exists between top and middle management. These are professional people, such as financial and marketing analysts that act as advisors and assistants to both top and middle management. They are responsible for finding or developing new knowledge (External Content) for the organization and integrating it with existing knowledge (Internal Content).
 - KMS that support these knowledge workers range from Internet search engines and expert systems, to Web-based computer-aided design and sophisticated data management systems

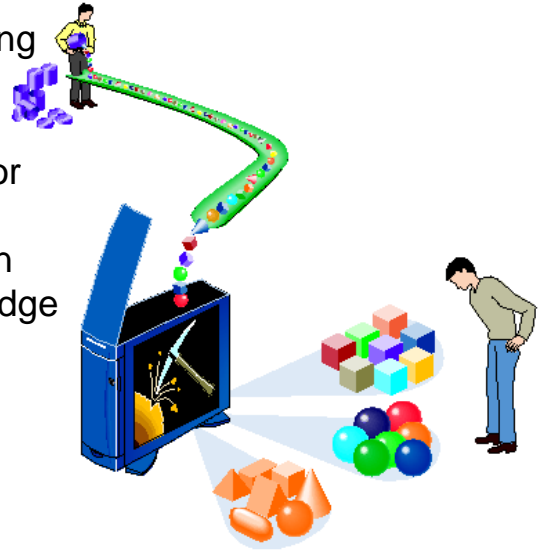

<http://dassy0105.wordpress.com>

02. Environments

- The Information Systems Support of People in Organizations

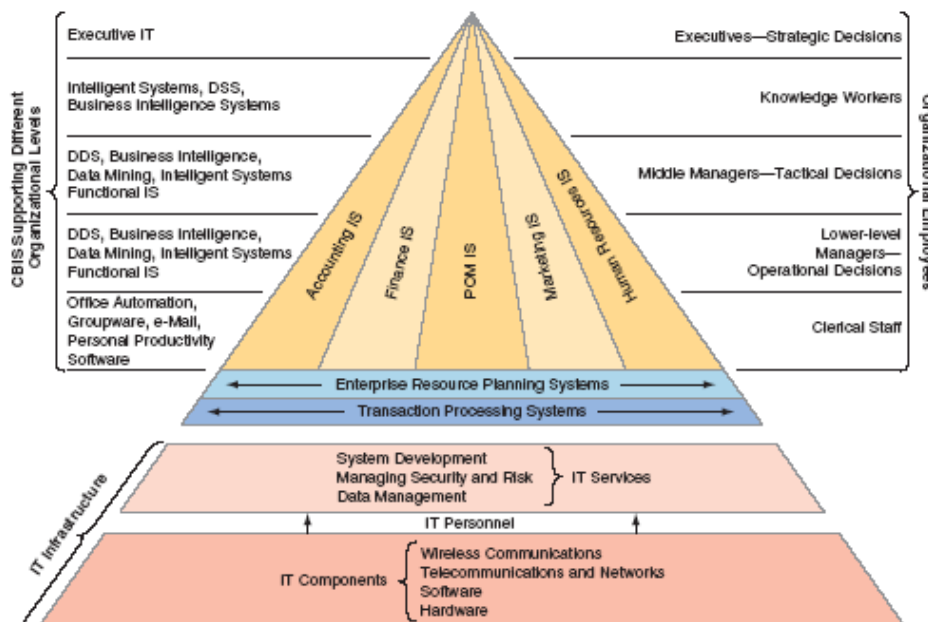

02. Environments

- Expand our Scope to Include External Environments
 - A supply chain is a concept describing the flow of materials, information, money, and services from raw material suppliers through factories and warehouses to the end customers.

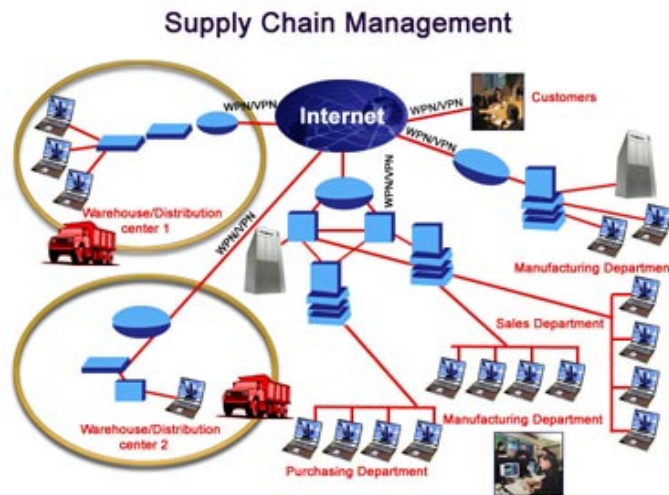

<http://www.erpsoftwares.net>

02. Environments

- Expand our Scope to Include External Environments
 - Components of the supply chain
 - Upstream supply chain
 - includes the organization's first-tier suppliers and their suppliers
 - Internal supply chain
 - includes all the processes used by an organization in transforming the inputs of the suppliers to outputs
 - Downstream supply chain
 - includes all the processes involved in delivering the products to final customers

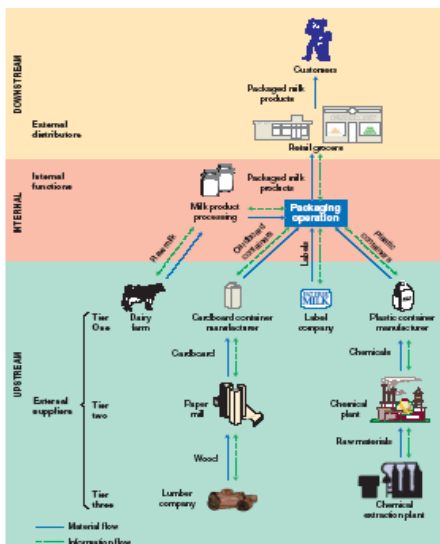

03. Inter-Organizational Systems

- Inter-Organizational Systems (IOS)
 - IOS are systems that connect two or more organizations. These systems are common among business partners and play a major role in e-commerce, as well as in supply chain management support.

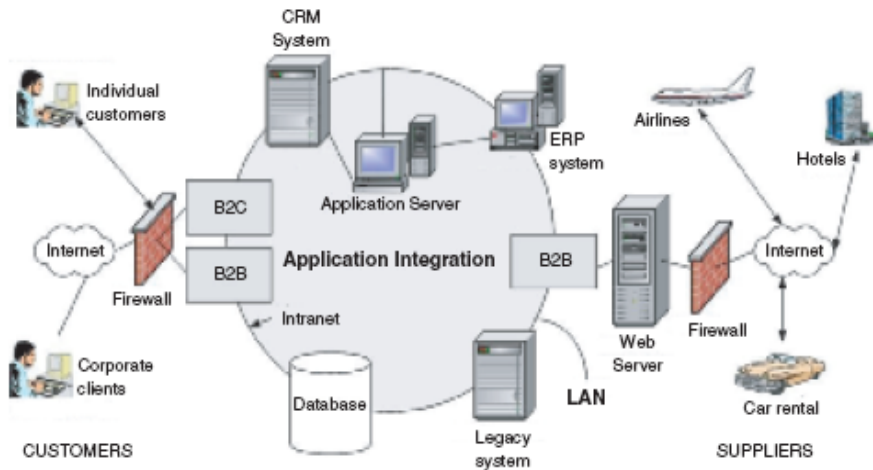

Information Technology for Management, Ed. 5, Efraim Turban et al., Wiley

03. Inter-Organizational Systems

- Inter-Organizational Systems (IOS)
 - The first type of IT system that was developed in the 1980s to improve communications with business partners was electronic data interchange (EDI), which involved computer-to-computer direct communication of standard business documents (such as purchase orders and order confirmations) between business partners. These systems became the basis for electronic markets, that later developed to electronic commerce.

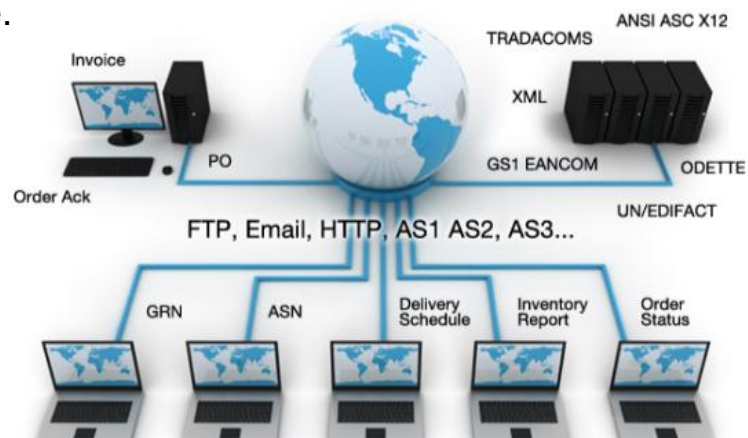

<http://www.perceptant.com>

03. Inter-Organizational Systems

- Inter-Organizational Systems (IOS)
 - Web-based systems (many using XML) deliver business applications via the Internet. Using browsers and the Internet, people in different organizations communicate, collaborate, access vast amounts of information, and run most of the organization's tasks and processes.



<http://www.priog.org>

04. Information Infrastructure

- Information Infrastructure
 - Hardware
 - Software
 - Networks & communication
 - Databases
 - IS personnel

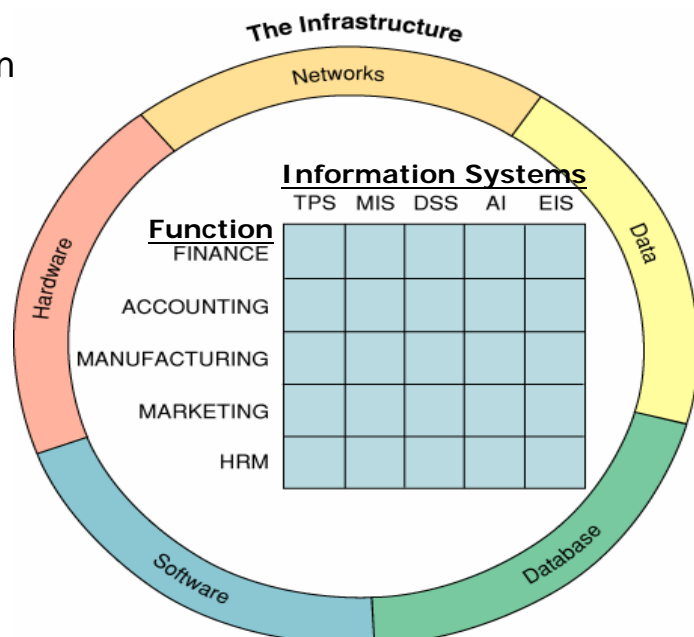

04. Information Infrastructure

- Information Architecture Classified by Hardware
 - A common way to classify information architecture is by computing paradigms, which are the core of the architecture.
 - Types
 - Enterprise-wide computing environment
 - Distributed computing environment
 - Client/server environment
 - Mainframe environment
 - PC-LAN environment
 - PC environment
 - Legacy systems



<http://curiouslee.typepad.com>

04. Information Infrastructure

- The Web Based IT Architectures
 - Web-based systems refer to those applications or services that are resident on a server that is accessible using a Web browser. The only client-side software needed to access and execute these applications is a Web browser environment.
 - Types
 - The Internet
 - Intranets
 - Extranets
 - Corporate portals
 - E-commerce systems
 - Electronic storefronts
 - Electronic markets
 - Electronic exchanges
 - M-commerce
 - Enterprise web



<http://www.acornsoftware.co.uk>

05. Internet

- Internet
 - Sometimes called simply “the Net,” the Internet is a worldwide system of computer networks— a network of networks hence Internet, in which users at any one computer can get information from any other computer
 - The Internet uses a portion of the total resources of the currently existing public telecommunication networks. Technically, what distinguishes the Internet is its use of a set of protocols called TCP/IP (Transmission Control Protocol/Internet Protocol).



<http://www.goomedic.com>

27

05. Internet

- Intranets
 - An intranet is the use of Web technologies to create a private network, usually within one enterprise.
 - It is typically a complete LAN, or several intra-connected LANs
 - Intranets are used for:
 - Work-group activities
 - The distributed sharing of projects within the enterprise
 - Controlled access to company financial documents
 - Use of knowledge management, research materials, online training, and other information that requires distribution within the enterprise.



<http://www.ecommerceconsortium.biz>

28

05. Internet

- Extranets
 - Connect several intranets via the Internet, by adding a security mechanism and some additional functionalities
 - They form a larger virtual network that allows remote users (such as business partners or mobile employees) to securely connect over the Internet to the enterprise's main intranet.
 - Extranets are also employed by two or more enterprises (suppliers & buyers) to share information in a controlled fashion, and therefore they play a major role in the development of business-to-business electronic commerce and Supply Chain systems.

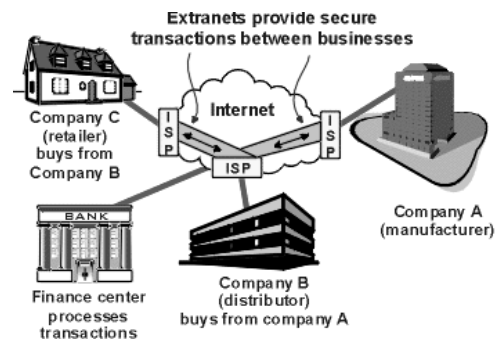

<http://www.mi-ip.com>

06. Corporate Portals

- Corporate Portals
 - Web sites that provide the gateway to corporate information from a single point of access. They aggregate information and content from many files and present it to the user.
 - Corporate portals also are used to personalize information for individual customers and for employees.
 - Intranets and Extranets are usually combined with and accessed via a corporate portal.

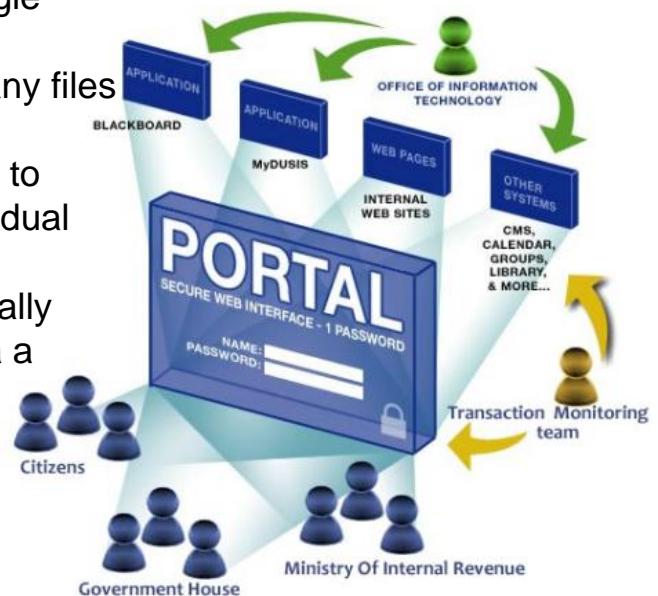

<http://www.newvital.com>

07. E-commerce Systems

- E-commerce Systems
 - Web-based systems that enable business transactions to be conducted seamlessly twenty-four hours a day, seven days a week
 - Some classifications of E-commerce systems are:
 - B2C (Business to Consumer)
 - B2B (Business to Business)
 - B2E (Business to Employee)
 - The major components of Web-based EC are:
 - Electronic storefronts
 - Electronic markets
 - Mobile commerce



<http://aff.ringtonepartner.com>

07. E-commerce Systems

- Electronic Storefronts
 - These are Web-equivalents of a physical store. Through the electronic storefront, an e-business can display and/or sell its products.
 - The storefront may include electronic catalogs that contain descriptions, graphics, and possibly product reviews.
 - They have following common features and functions:
 - E-catalog
 - Shopping cart
 - Checkout mechanism
 - Payment processing feature
 - Back office order fulfillment system



<http://www.koreaitimes.com>

07. E-commerce Systems

- Electronic Markets

- Is a web-based network of interactions and relationships over which information, products, services, and payments are exchanged. It is equivalent to a physical marketplace except is Web-based.
- The principal participants in marketplaces are: transaction handlers, buyers, brokers, and sellers.
- The means of interconnection vary among parties and can change from event to event, even between the same parties. Electronic markets can reside in one company, where there is either one seller and many buyers, or one buyer and many sellers. These are referred to as private marketplaces.

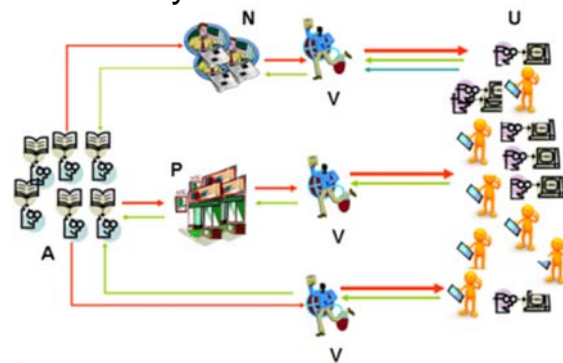

<http://www.icrossword.com>

33

07. E-commerce Systems

- Electronic Exchanges

- A special form of electronic markets which are Web-based public marketplaces where many buyers and many sellers interact dynamically.
- Originally set as trading places for commodities, electronic exchanges have emerged for all kinds of products and services.



<http://smallbusinessindia.intuit.in>

34

07. E-commerce Systems

- M-Commerce– Mobile Computing
 - M-commerce or Mobile commerce is commerce (buying and selling of goods and services) in a wireless environment, such as through wireless devices like cellular telephones and PDAs.
 - M-commerce enables users to access the Internet without needing to find a place to “plug” in their device.
 - As this wireless environment expands, a pervasive computing environment will develop, employed by mobile employees and others, will change the way business is transacted.



<http://www.mobilemarketingwatch.com>

35

08. Enterprise Web

- Is an open environment for managing and delivering Web applications. It combines services from different vendors in a technology layer that spans rival platforms and business systems, creating a foundation for building applications at a lower cost.
- Applications, including business integration, collaboration, content management, identity management, and search, which work together via integrating technologies.
- The result is an environment that spans the entire enterprise.



<http://www.ikmtechnology.com>

36

09. New Computing Environments

- Utility Computing
 - Utility Computing is computing that is as available, reliable, and secure as electricity, water services, and telephony.
 - The vision behind utility computing is to have computing resources flow like electricity on demand from virtual utilities around the globe—always on and highly available, secure, efficiently metered, priced on a pay-as-you-use basis, dynamically scaled, self-healing, and easy to manage.



<http://calenlegaspi.blogspot.com>

09. New Computing Environments

- Subscription Computing
 - Subscription Computing is a form of utility computing that puts the pieces of a computing platform together as services, rather than as a collection of separately purchased components.

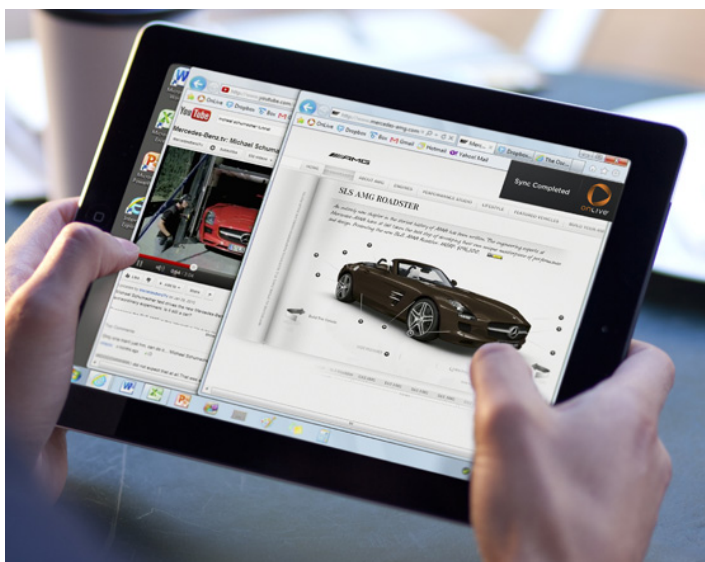

<http://www.windowsitpro.com>

09. New Computing Environments

- Grid Computing
 - Grid Computing employs networked systems to harness the unused processing cycles of all computers in that given network thus creating powerful computing capabilities.
 - Grid computing is already in limited use, for example the well-known grid-computing project SETI (Search for Extraterrestrial Intelligence) @Home project. In this project, PC users worldwide donate unused processor cycles to help the search for signs of extraterrestrial life by analyzing signals coming from outer space.

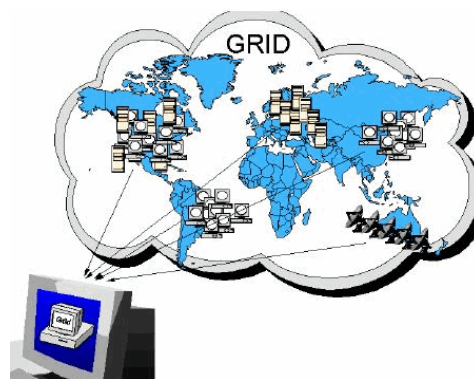

<http://uaegrid.uae.ac.ma>

09. New Computing Environments

- Pervasive Computing
 - In the future, computation becomes part of the environment.
 - Computation will be embedded in things, not in computers.



<http://albrecht-schmidt.blogspot.com>

09. New Computing Environments

- Web Services
 - Web services are self-contained, self-describing business and consumer modular applications, delivered via the Internet, that users can select and combine through almost any device, ranging from PC to mobile phones.



<http://en.wikipedia.org>



<http://www.cyber-swift.com>

10. Managing Information Systems

- Information Systems (IS) have enormous strategic value so when they are not working even for a short time, an organization cannot function.
- Furthermore, the Life Cycle Costs (acquisition, operation, security, and maintenance) of these systems is considerable.
- Therefore, it is essential to manage them properly.
- The planning, organizing, implementing, operating, and controlling of the infrastructures and the organization's portfolio of applications must be done with great skill.



10. Managing Information Systems

- The responsibility for the management of information resources is divided between two organizational entities:
 - The information systems department (ISD), which is a corporate entity
 - The end users, who are scattered throughout the organization.

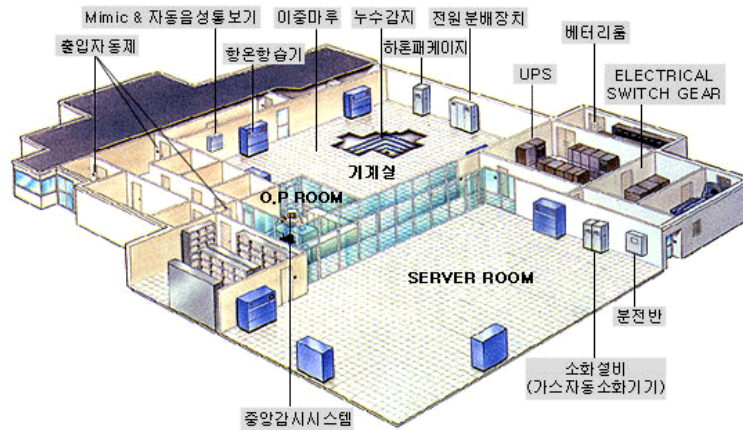

<http://www.jinyangts.com>